



## DOCUMENTATION SHEET

### Steel Spring Isolator Type LR

# LR

#### General

The helical spring isolators are enclosed in aluminum castings, the top interlocking with the base. A built-in leveling device is adjustable by the supplied top fixing screw. A molded neoprene O-ring prevents metal to metal contact of the casting and forms a seal against the weather and contaminants.

Low profile multiple spring isolators type MS, LS, LR, LRH and LRX are available for a load range up to 42.2 kN.

#### Applications

- Generator sets
- Emergency power supplies
- DC-AC converters
- Industrial fans
- Air-handling units
- Air-conditioning machines
- Compressor packages
- Electrical equipment
- Refrigerators
- Cooler units

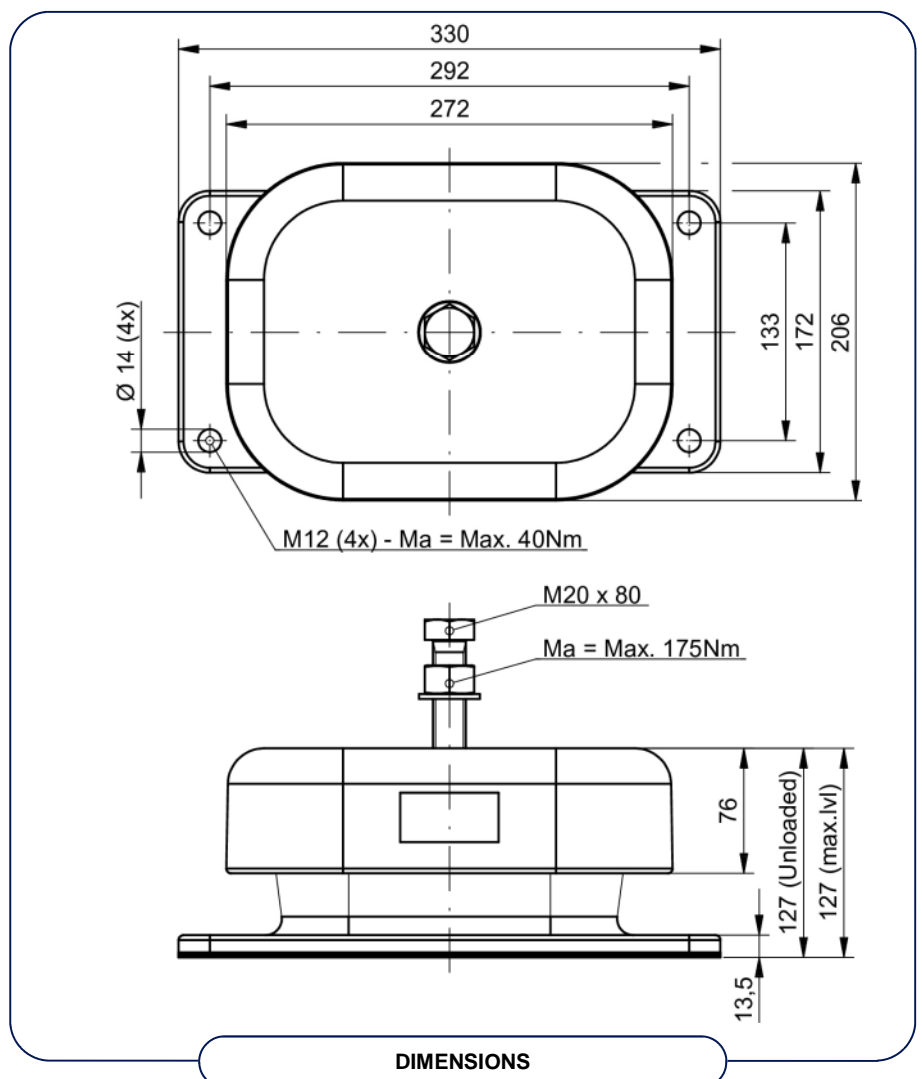



| Type   | Cz [N/mm] | Cx, y [N/mm]<br>at preferential<br>load | Fz max [N] | Fz preferential [N] |
|--------|-----------|---|------------|---------------------|
| LR2100 | 368,2     | 258,9                                   | 9353       | 8043                |
| LR2400 | 420,3     | 295,5                                   | 10676      | 9248                |
| LR2700 | 473,4     | 346,0                                   | 12010      | 10402               |
| LR3000 | 525,3     | 396,0                                   | 13344      | 11556               |
| LR3300 | 577,9     | 432,4                                   | 14679      | 12712               |
| LR3600 | 630,4     | 465,1                                   | 16013      | 13869               |
| LR3900 | 683,0     | 505,2                                   | 17348      | 15026               |
| LR4200 | 735,5     | 534,0                                   | 18682      | 16182               |
| LR4500 | 788,0     | 562,4                                   | 20017      | 17338               |
| LR4800 | 840,6     | 591,0                                   | 21351      | 18494               |
| LR5800 | 1360,0    | 815,0                                   | 25804      | 22279               |
| LR6800 | 1594,0    | 956,0                                   | 30257      | 26065               |
| LR7800 | 1828,0    | 1149,0                                  | 34710      | 29850               |

## CHARACTERISTICS

### Isolator selection

This described isolator selection is based on the vertical load of the isolators, if required seismic and 6 DOF calculations can be performed by our specialists.

1. Determine the total weight of the machine to be isolated, including work load
2. Determine the position of the combined centre of gravity in horizontal and vertical planes
3. Decide the number of isolators and the positions where the isolators are to be placed relative to the combined centre of gravity
4. Calculate the load per isolator
5. Select with the help of the preferential load in the table the suitable type of mounting

We recommend selection of the isolators be made with the load per isolator within + or - 10% of the preferential load. The static deflection of the isolator is calculated by dividing the load per isolator by the stiffness Cz given in the table for the selected isolator.

LR

### Rubber Design B.V.

Industrieweg 21

2995BE Heerjansdam

The Netherlands

Phone: +31 (0)78 677 87 78

Email: [info@rubberdesign.nl](mailto:info@rubberdesign.nl)

Web: [www.rubberdesign.nl](http://www.rubberdesign.nl)